

1414 PH Series Enclosures - NEMA 12, 13

Continuous Hinge, Clamped Cover

Industrial Enclosures

Junction Boxes

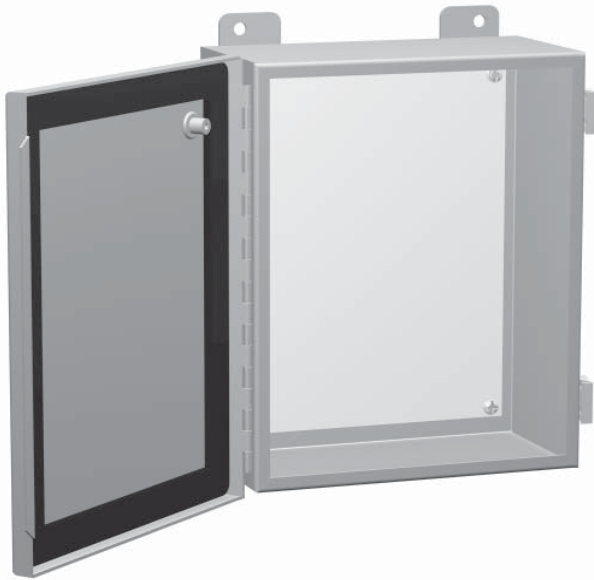

**Inner
Panel
Included**



Application

- Designed for use as instrument enclosures, electric, hydraulic or pneumatic control housings, electrical junction boxes or terminal wiring enclosures.
- Provides a degree of protection from falling dirt, dust, oil and water.

Standards

- UL 508 Type 12, 13
- CSA Type 12, 13
- **Complies with**
 - NEMA Type 12 and 13
 - JIC EGP-1-1967 unless marked¹
 - IEC 60529, IP54

Construction

- Body formed from 16 gauge or 14 gauge steel. Covers are formed from 14 gauge steel.
- Smooth, continuously welded seams without knockouts, cutouts or holes.
- Welded brackets provide for enclosure mounting.
- Continuously hinged cover is secured with stainless steel clamps and plated steel screws.
- Seamless poured-in place gasket.
- Models larger than 4" x 4" include a removable 14 gauge inner panel.
- Internal threaded weld studs are provided for mounting inner panels.
- A bonding stud is provided on the door and a grounding stud is provided in the enclosure.

Finish

- Cover and enclosure are phosphatized and finished in ANSI 61 gray recoatable powder coating.
- Removable inner panel is finished in white powder coating.

Accessories

- Additional inner panels...*see page 436*
- Breather kits...*see page 400-401*
- Door clamping hardware...*see page 429*
- Filter fans...*see page 371-384*
- Heaters...*see page 393-396*
- Louvered ventilating plates...*see page 402*
- Terminal kit assemblies...*see page 441*
- Thermostats...*see page 397*
- Swing panel...*see page 440*

1414 PH Series Enclosures - NEMA 12, 13

Continuous Hinge, Clamped Cover

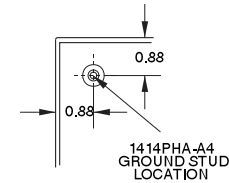
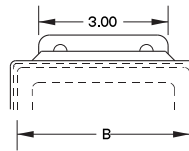
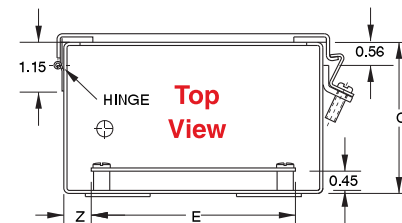
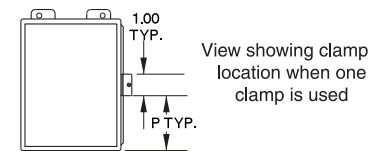
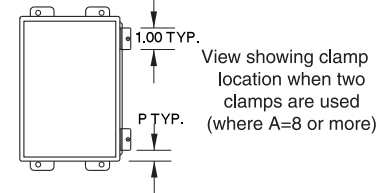
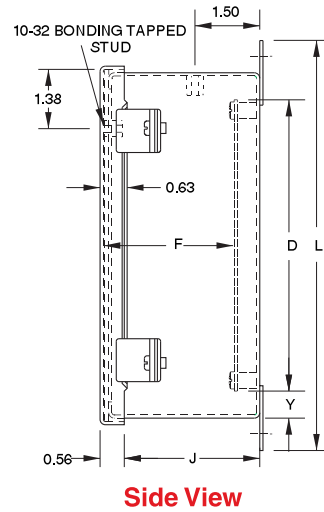
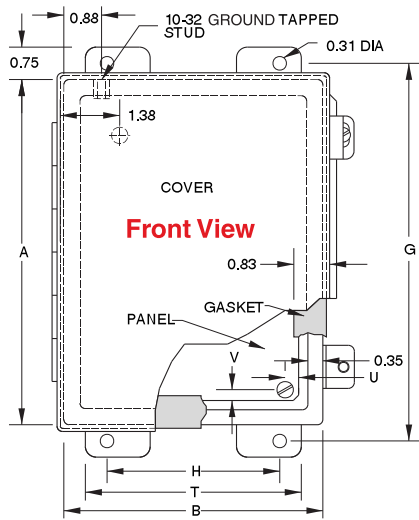

Part No.	Part No. Without Inner Panel	Panel Size										Cover Dimensions							Ship wt. w/Pnl	Ship wt. n/Pnl			
		A	B	C	D	E	F	G	H	J	L	P	T	U	V	Y	Z						
—	1414PHA ¹	4	4	3.0	—	—	—	4.75	2	2.64	5.5	4.31	4.31	1.5	3	—	—	—	—	—	—	—	2
1414PHC ¹	1414PHCLP ¹	6	4	3.0	4.88	2.88	2.51	6.75	2	2.64	7.5	6.31	4.31	2.5	3	.31	.31	.56	.56	3	3	2	
1414PHG	1414PHGLP	8	6	3.5	6.75	4.88	3.01	8.75	4	3.14	9.5	8.31	6.31	1.0	5	.31	.25	.63	.56	6	5		
1414PHRG	1414PHRGLP	6	8	3.5	4.88	6.75	3.01	6.75	6	3.14	7.5	6.31	8.31	2.5	7	.25	.31	.56	.63	6	5		
—	1414PHA ¹	4	4	4.0	—	—	—	4.75	2	3.64	5.5	4.31	4.31	1.5	3	—	—	—	—	—	—	3	
1414PHC ¹	1414PHC4LP ¹	6	4	4.0	4.88	2.88	3.51	6.75	2	3.64	7.5	6.31	4.31	2.5	3	.31	.31	.56	.56	4	3		
1414PHE	1414PHELP	6	6	4.0	4.88	4.88	3.51	6.75	4	3.64	7.5	6.31	6.31	2.5	5	.31	.31	.56	.56	5	4		
1414PHH4	1414PHH4LP	8	8	4.0	6.75	6.88	3.51	8.75	6	3.64	9.5	8.31	8.31	1.0	7	.31	.25	.63	.56	8	7		
1414PHI	1414PHILP	10	8	4.0	8.75	6.88	3.51	10.75	6	3.64	11.5	10.31	8.31	1.0	7	.31	.25	.63	.56	10	8		
1414PHRI	1414PHRILP	8	10	4.0	6.88	8.75	3.51	8.75	8	3.64	9.5	8.31	10.31	1.0	9	.25	.31	.56	.63	10	8		
1414PHKC4	1414PHKC4LP	12	6	4.0	10.75	4.88	3.51	12.75	4	3.64	13.5	12.31	6.31	1.0	5	.31	.25	.63	.56	10	8		
1414PHK	1414PHKLP	12	10	5.0	10.75	8.88	4.51	12.75	8	4.64	13.5	12.31	10.31	1.0	9	.31	.25	.63	.56	13	10		
1414PHRK	1414PHRKLP	10	12	5.0	8.88	10.75	4.51	10.75	10	4.64	11.5	10.31	12.31	1.0	11	.25	.31	.56	.63	13	12		
1414PHG6	1414PHG6LP	8	6	6.0	6.75	4.88	5.51	8.75	4	5.64	9.5	8.31	6.31	1.0	5	.31	.25	.63	.56	8	7		
1414PHI6	1414PHI6LP	10	8	6.0	8.75	6.88	5.51	10.75	6	5.64	11.5	10.31	8.31	1.0	7	.31	.25	.63	.56	12	10		
1414PHJ6	1414PHJ6LP	10	10	6.0	8.75	8.88	5.51	10.75	8	5.64	11.5	10.31	10.31	1.0	9	.31	.25	.63	.56	14	12		
1414PHL6	1414PHL6LP	12	12	6.0	10.75	10.88	5.51	12.75	10	5.64	13.5	12.31	12.31	1.0	11	.31	.25	.63	.56	17	15		
1414PHMH6	1414PHMH6LP	14	8	6.0	12.75	6.88	5.51	14.75	6	5.64	15.5	14.31	8.31	1.0	7	.31	.25	.63	.56	12	10		
1414PHM6	1414PHM6LP	14	12	6.0	12.75	10.88	5.51	14.75	10	5.64	15.5	14.31	12.31	1.0	11	.31	.25	.63	.56	19	17		
1414PHRM6	1414PHRM6LP	12	14	6.0	10.88	12.75	5.51	12.75	12	5.64	13.5	12.31	14.31	1.0	13	.25	.31	.56	.63	19	17		
1414PHN6	1414PHN6LP	16	10	6.0	14.75	8.88	5.51	16.75	8	5.64	17.5	16.31	10.31	1.0	9	.31	.25	.63	.56	18	15		
1414PHO6	1414PHO6LP	16	14	6.0	14.75	12.88	5.51	16.75	12	5.64	17.5	16.31	14.31	1.0	13	.31	.25	.63	.56	23	21		
1414PHRO6	1414PHRO6LP	14	16	6.0	12.88	14.75	5.51	14.75	14	5.64	15.5	14.31	16.31	1.0	15	.25	.31	.56	.63	23	21		
1414PHK8	1414PHK8LP	12	10	8.0	10.75	8.88	7.51	12.75	8	7.64	13.5	12.31	10.31	1.0	9	.31	.25	.63	.56	18	15		
1414PHM8	1414PHM8LP	14	12	8.0	12.75	10.88	7.51	14.75	10	7.64	15.5	14.31	12.31	1.0	11	.31	.25	.63	.56	20	18		
1414PHO8	1414PHO8LP	16	14	8.0	14.75	12.88	7.51	16.75	12	7.64	17.5	16.31	14.31	1.0	13	.31	.25	.63	.56	25	22		
1414PHO10	1414PHO10LP	16	14	10.0	14.75	12.88	9.51	16.75	12	9.64	17.5	16.31	14.31	1.0	13	.31	.25	.63	.56	26	23		

¹ Does not meet JIC requirements